

(19) World Intellectual Property Organization
International Bureau



(43) International Publication Date
23 March 2006 (23.03.2006)

PCT

(10) International Publication Number
WO 2006/029456 A1

- (51) International Patent Classification: ⁷ B01D 65/02
- (21) International Application Number:
PCT/AU2005/001396
- (22) International Filing Date:
13 September 2005 (13.09.2005)
- (25) Filing Language: English
- (26) Publication Language: English
- (30) Priority Data:
2004905292 14 September 2004 (14.09.2004) AU
- (71) Applicant (for all designated States except US): U. S. FILTER WASTEWATER GROUP, INC. [US/US]; 181 Thorn Hill Road, Warrendale, PA 15086 (US).
- (72) Inventors; and
- (75) Inventors/Applicants (for US only): BECK, Thomas, William [AU/AU]; 121 Keda Circuit, North Richmond, NSW 2756 (AU). JOHNSON, Warren, Thomas [AU/AU]; 87 Avoca Road, Grose Wold, NSW 2753 (AU).
- (74) Agent: SHELSTON IP; 60 Margaret Street, Sydney, NSW 2000 (AU).

(81) Designated States (unless otherwise indicated, for every kind of national protection available): AE, AG, AL, AM, AT, AU, AZ, BA, BB, BG, BR, BW, BY, BZ, CA, CH, CN, CO, CR, CU, CZ, DE, DK, DM, DZ, EC, EE, EG, ES, FI, GB, GD, GE, GH, GM, HR, HU, ID, IL, IN, IS, JP, KE, KG, KM, KP, KR, KZ, LC, LK, LR, LS, LT, LU, LV, MA, MD, MG, MK, MN, MW, MX, MZ, NA, NG, NI, NO, NZ, OM, PG, PH, PL, PT, RO, RU, SC, SD, SE, SG, SK, SL, SM, SY, TJ, TM, TN, TR, TT, TZ, UA, UG, US, UZ, VC, VN, YU, ZA, ZM, ZW.

(84) Designated States (unless otherwise indicated, for every kind of regional protection available): ARIPO (BW, GH, GM, KE, LS, MW, MZ, NA, SD, SL, SZ, TZ, UG, ZM, ZW), Eurasian (AM, AZ, BY, KG, KZ, MD, RU, TJ, TM), European (AT, BE, BG, CH, CY, CZ, DE, DK, EE, ES, FI, FR, GB, GR, HU, IE, IS, IT, LT, LU, LV, MC, NL, PL, PT, RO, SE, SI, SK, TR), OAPI (BF, BJ, CF, CG, CI, CM, GA, GN, GQ, GW, ML, MR, NE, SN, TD, TG).

Declaration under Rule 4.17:

— of inventorship (Rule 4.17(iv)) for US only

[Continued on next page]

(54) Title: METHODS AND APPARATUS FOR REMOVING SOLIDS FROM A MEMBRANE MODULE

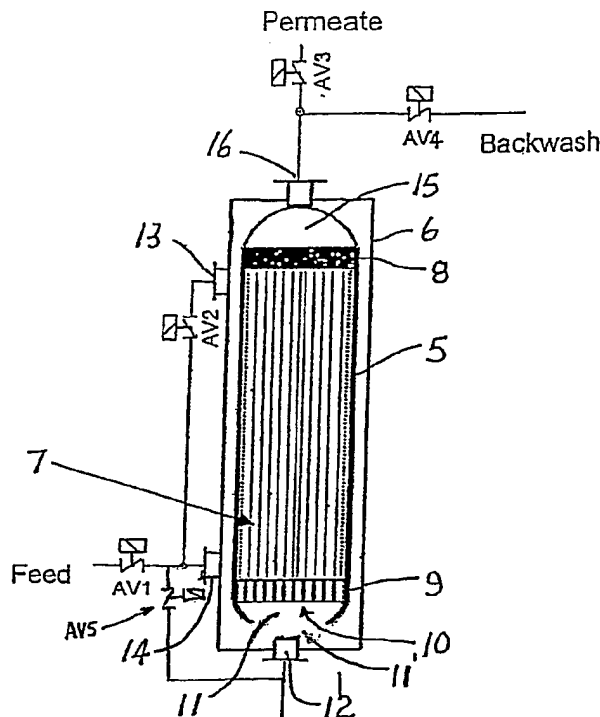

(57) Abstract: A method of operating a membrane filtration module (5), the module (5) including one or more membranes (7) extending longitudinally between vertically spaced upper and lower headers (8, 9) into which the ends of the membranes (7) are potted. The membranes (7) have a permeable wall which is subjected to a filtration operation wherein feed containing contaminant matter is applied to one side of the membrane wall and filtrate is withdrawn from the other side of the membrane wall. At least one of the upper and/or lower headers (8, 9) has one or more openings (10) therein and the method including flowing the feed, at least in part, through the one or more openings (10) for application to the membrane wall. Apparatus for performing the method is also disclosed.

WO 2006/029456 A1



Published:

— *with international search report*

For two-letter codes and other abbreviations, refer to the "Guidance Notes on Codes and Abbreviations" appearing at the beginning of each regular issue of the PCT Gazette.

METHODS AND APPARATUS FOR REMOVING SOLIDS FROM A MEMBRANE MODULE

FIELD OF THE INVENTION

The present invention relates to membrane filtration systems and, more
5 particularly, to a method and apparatus for improving the filtration efficiency of
such systems by providing an improved cleaning system for the membranes.

BACKGROUND ART

In a membrane filtration process, the method used to physically clean
membranes is of vital importance. An efficient membrane cleaning strategy can
10 maintain a stable permeability of the membrane and reduce the frequency of
chemical cleans. A commonly used method to physically clean membranes is a
backwash (also called "backflush" or "backpulse") with the permeate/filtrate or a
gas. The backwash method is typically used to eject solids blocking the
membrane pores and partly dislodge the cake that may have formed on the
15 membrane surface. In a system exposed to a feed containing a high concentration
of solids, the fouling occurs more quickly and more severely, in particular, where
membranes are densely packed in a module.

Backwash with pressurized gas has proved a very efficient cleaning
method and is now widely used in the field of microfiltration processes. The
20 limitation to this method is the membrane pore size. Backwash of membranes
with permeate has no limitations to the pore size, but the backwash efficiency is
generally lower than gas backwash and the transmembrane pressure (TMP)
recovery is not enough to offset the fouling rate. Further means are employed to
enhance the backwash efficiency, such as dosing chemicals to the backwash
25 permeate, or in combination with gas scrubbing.

Maruyama et al in Japanese Patent No. JP2031200 discloses a hollow fibre membrane backwashing method. The method involves the following sequence: stop filtration, air-scour membrane, fill the membrane vessel, backwash with permeate under pressurized air and drain the waste. This procedure is repeated to achieve a higher efficiency. Sunaoka et al in a United States Patent No. 5,209,852 describes a process for scrubbing hollow fibre membranes in modules. This process is composed of a two-stage air scrubbing and draining to clean the membranes.

In order to minimise footprint and cost, membrane modules are typically manufactured with a high packing density of membranes, usually in the form of fibres. This increases the amount of membrane area for filtration within a module. However, the higher the packing density the more difficult it is to effectively flush solids captured during the filtration process from the membrane bundle. Therefore, improvement in the efficiency of solids removal during backwash allows either higher solids levels to be processed, or higher membrane packing densities to be used, reducing the cost of treatment.

In prior art fibre membrane systems, removal of solids is usually effected by sweeping with feedwater from one end of the module to the other and then out of the module through a side exit port. In this case, solids are first swept along the fibres to the exit end of the module, but must then cross the fibre bundle to exit the module. In many applications this requirement for the flow to change direction and pass perpendicular to the fibre bundle to exit the module can lead to accumulation of solids near the exit due to the tendency for the fibres to act like a string filter and capture or hinder the exit of solids from the module at this point.

DISCLOSURE OF THE INVENTION

The present invention seeks to overcome or at least ameliorate one or more of the disadvantages of the prior art or at least provide a useful alternative.

According to one aspect, the present invention provides a method of
5 operating a membrane filtration module, said module including one or more membranes extending longitudinally between vertically spaced upper and lower headers into which the ends of the membranes are potted, the membranes having a permeable wall which is subjected to a filtration operation wherein feed containing contaminant matter is applied to one side of the membrane wall and
10 filtrate is withdrawn from the other side of the membrane wall, at least one of said upper and/or lower headers having one or more openings therein, the method including flowing said feed, at least in part, through said one or more openings for application to said membrane wall.

According to another aspect, the present invention provides a method of
15 cleaning a membrane filtration module, said module including one or more membranes located in a feed-containing vessel and extending longitudinally between vertically spaced upper and lower headers into which the ends of the membranes are potted, the membranes having a permeable wall which is subjected to a filtration operation wherein feed containing contaminant matter is
20 applied to one side of the membrane wall and filtrate is withdrawn from the other side of the membrane wall, at least one of said upper and/or lower headers having one or more openings therein, the method including:

- a) performing a filtration operation wherein said feed, at least in part, is
flowed through said one or more openings for application to said
25 membrane wall;

- 4 -

- b) suspending the filtration operation;
- c) performing a cleaning process on the membrane wall to dislodge contaminant matter therefrom into liquid surrounding the membrane;
- d) performing a sweep of the feed-containing vessel substantially parallel
5 to the longitudinally extending membranes to remove the liquid containing the dislodged contaminant matter, at least in part, through the openings in the header; and
- e) recommencing the filtration operation.

For further preference, the openings are provided in the lower header and
10 filtrate is withdrawn from the upper header. Preferably, the openings may also be used to introduce gas into the module to produce bubbles for scouring the surface of the membranes during said cleaning process. The sweep may be performed concurrently with the cleaning process. Preferably, the sweep is a high velocity sweep.

15 The present invention provides for holes or openings in one of the module pots so that during filtration at least part of the feed liquid will also be drawn in through the openings in the bottom pot and flow into the depths of the membrane bundle, reducing shell side pressure drop and generating some crossflow over the membrane surface. The use of these holes or openings for
20 waste flow also allows solids swept along the membranes during the backwash process to continue to flow parallel to the membranes as they exit the module. The requirement for the solids to cross over the fibre bundle to exit at a side port is substantially reduced or eliminated.

The same concept may be applied to submerged membranes operated in
25 an open tank. In the prior art, solids are typically removed by draining the tank.

- 5 -

As the feed containing the solids drains from the module it must change direction near the bottom to flow out of the module and drain from the tank. By providing holes or openings in the bottom of the module, solids can continue to flow substantially parallel to the fibres as they pass out of the module. This
5 uninterrupted flow provides for more efficient removal of solid from the module and tank.

According to a further aspect, the present invention provides a method of operating a membrane filtration module, said module including one or more membranes extending vertically from an upper header into which proximal ends
10 of the membranes are potted, the membranes having a permeable wall which is subjected to a filtration operation wherein feed containing contaminant matter is applied to one side of the membrane wall and filtrate is withdrawn from the other side of the membrane wall, the method including during said filtration operation flowing said feed, at least in part, through one or more openings in the module
15 below said membranes for application to said membrane wall.

According to yet a further aspect, the present provides a method of cleaning a membrane filtration module, said module including one or more membranes located in a feed-containing vessel and extending vertically from an upper header into which proximal ends of the membranes are potted, the
20 membranes having a permeable wall which is subjected to a filtration operation wherein feed containing contaminant matter is applied to one side of the membrane wall and filtrate is withdrawn from the other side of the membrane wall, the method including:

- 6 -

- a) performing a filtration operation wherein said feed, at least in part, is flowed through one or more openings in the module below said membranes for application to said membrane wall;
- b) suspending the filtration operation;
- 5 c) performing a cleaning process on the membrane wall to dislodge contaminant matter therefrom into liquid surrounding the membrane;
- d) performing a sweep or drain-down of the feed-containing vessel substantially parallel to the vertically extending membranes to
10 remove the liquid containing the dislodged contaminant matter, at least in part, through said opening or openings in the module beneath said membranes; and
- e) recommencing the filtration operation.

Apparatus for performing the above methods is also included within the
15 scope of the present invention.

BRIEF DESCRIPTION OF THE DRAWING

Embodiments of the invention will now be described, by way of example only, with reference to the accompanying drawings in which:

Figure 1 shows a schematic sectional view of a membrane module
20 according to one embodiment;

Figure 2 shows a schematic sectional view of a membrane module according to further embodiment; and

Figures 3a and 3b show an enlarged schematic sectional view of the lower header of a non-pressurized filtration system during the aeration and drain-down
25 phases, respectively.

DESCRIPTION OF PREFERRED EMBODIMENTS

Referring to the Figure 1, the filtration module 5 is mounted within a housing vessel 6 which contains the feed to be filtered. The filtration module 5 contains a bundle or bundles of hollow fibre membranes 7 extending between upper and lower headers 8 and 9, respectively. The lower header 9 is provided with a number of openings 10 communicating with the interior of the fibre bundle and an open-ended plenum chamber 11 having an opening 11'. An inlet/outlet port 12 is provided at the base of the module 5. Feed is supplied through ports 12, 13 and 14 under the control of valves AV5, AV1 and AV2.

10 Permeate/filtrate is withdrawn through chamber 15 and port 16 under control of valve AV3. A backwash may also be applied through port 16 under the control of valve AV4.

Figure 2 shows a similar arrangement to Figure 1, however, in this embodiment the hollow fibre membranes 7 are suspended vertically from the upper header 8 and are not potted at their lower distal ends 19. The distal ends 19 of each fibre membrane 7 are closed and filtrate withdrawn through the upper header 8.

In use, solids accumulated within the modules 5 following filtration and backwash are flushed or swept from the modules 5 through the openings 10 by opening port 12 and applying a suitable pressure to the feed within the module 5. The waste is flushed through the opening 11' in the plenum chamber 11 and removed through open port 12.

Figures 3a and 3b show an enlarged view of the lower headers 9 of a pair of modules 5 connected to a single plenum chamber 11 in a non-pressurized filtration system. The modules 5 in this embodiment are mounted in an open

vessel (not shown) and the waste liquid containing solids accumulated within the modules 5 following filtration and backwash is drained through the openings 10 under force of gravity, as shown in Figure 3b.

As best shown in Figure 3a, port 17 connected to a gas supply manifold 18
5 may also be used to supply gas to openings 10 to provide scouring bubbles within the module 5 to assist cleaning of the fibre membrane surfaces.

Systems embodying the invention may provide a number of benefits including:

1. Enhanced solids removal during backwash due to sweeping action
10 along the fibre surface rather than across multiple fibres.
2. Easier contact of feed liquid with the inside of the membrane bundle during filtration (feed liquid can be drawn into the centre of the bundle through the same holes during filtration). This also induces a form of crossflow during filtration.
- 15 3. Rack inserts containing sets of membrane modules can be lowered down closer to the bottom of the module as an open area is no longer required beneath the modules to accommodate manifolds and piping used for solids removal and feed inlet, this now takes place through the openings in the pot. The result is better void space reduction efficiency as well as less space for
20 drainage.
4. The plenum chambers can be connected to a pipe or manifold and the backwash waste pumped out of the module rather than gravity flowed, and/or the feedwater pumped in during filtration.

It will be appreciated that further embodiments and exemplifications of the invention are possible with departing from the spirit or scope of the invention described.

CLAIMS:

1. A method of operating a membrane filtration module, said module including one or more membranes extending longitudinally between vertically spaced upper and lower headers into which the ends of the membranes are potted, the membranes having a permeable wall which is subjected to a filtration operation wherein feed containing contaminant matter is applied to one side of the membrane wall and filtrate is withdrawn from the other side of the membrane wall, at least one of said upper and/or lower headers having one or more openings therein, the method including flowing said feed, at least in part, through said one or more openings for application to said membrane wall.

2. A method of cleaning a membrane filtration module, said module including one or more membranes located in a feed-containing vessel and extending longitudinally between vertically spaced upper and lower headers into which the ends of the membranes are potted, the membranes having a permeable wall which is subjected to a filtration operation wherein feed containing contaminant matter is applied to one side of the membrane wall and filtrate is withdrawn from the other side of the membrane wall, at least one of said upper and/or lower headers having one or more openings therein, the method including:

a) performing a filtration operation wherein said feed, at least in part, is flowed through said one or more openings for application to said membrane wall;

b) suspending the filtration operation;

- 11 -

- c) performing a cleaning process on the membrane wall to dislodge contaminant matter therefrom into liquid surrounding the membrane;
 - d) performing a sweep or drain-down of the feed-containing vessel substantially parallel to the longitudinally extending membranes to
5 remove the liquid containing the dislodged contaminant matter, at least in part, through the openings in the header; and
 - e) recommencing the filtration operation.
3. A method of cleaning a membrane filtration module according to claim 2 wherein the openings are provided in the lower header and filtrate is withdrawn
10 from the upper header.
4. A method of cleaning a membrane filtration module according to claim 3 wherein the openings are used to introduce gas into the module to produce bubbles for scouring the surface of the membranes during said cleaning process.
- 15 5. A method of cleaning a membrane filtration module according to claim 2 wherein the sweep is performed concurrently with the cleaning process.
6. A method of cleaning a membrane filtration module according to claim 2 or claim 5 wherein the sweep is a high velocity sweep.
7. A method of cleaning a membrane filtration module according to claim 2
20 wherein the feed-containing vessel is open to atmosphere.
8. A method of operating a membrane filtration module, said module including one or more membranes extending vertically from an upper header into which proximal ends of the membranes are potted, the membranes having a permeable wall which is subjected to a filtration operation wherein feed
25 containing contaminant matter is applied to one side of the membrane wall and

filtrate is withdrawn from the other side of the membrane wall, the method including during said filtration operation flowing said feed, at least in part, through one or more openings in the module below said membranes for application to said membrane wall.

- 5 9. A method of cleaning a membrane filtration module, said module including one or more membranes located in a feed-containing vessel and extending vertically from an upper header into which proximal ends of the membranes are potted, the membranes having a permeable wall which is subjected to a filtration operation wherein feed containing contaminant matter is
- 10 applied to one side of the membrane wall and filtrate is withdrawn from the other side of the membrane wall, the method including:
- a) performing a filtration operation wherein said feed, at least in part, is flowed through one or more openings in the module below said membranes for application to said membrane wall;
 - 15 b) suspending the filtration operation;
 - c) performing a cleaning process on the membrane wall to dislodge contaminant matter therefrom into liquid surrounding the membrane;
 - d) performing a sweep or drain-down of the feed-containing vessel substantially parallel to the vertically extending membranes to remove
 - 20 the liquid containing the dislodged contaminant matter, at least in part, through said opening or openings in the module beneath said membranes; and
 - e) recommencing the filtration operation.

- 13 -

10. A membrane filtration module including one or more membranes extending longitudinally between vertically spaced upper and lower headers into which the ends of the membranes are potted, the membranes having a permeable wall which is subjected to a filtration operation wherein feed
5 containing contaminant matter is applied to one side of the membrane wall and filtrate is withdrawn from the other side of the membrane wall, at least one of said upper and/or lower headers having one or more openings therein and means for flowing said feed, at least in part, through said one or more openings for application to said membrane wall.
- 10 11. A membrane filtration module according to claim 10 wherein the openings are provided in the lower header and filtrate is withdrawn from the upper header.
12. A membrane filtration module according to claim 10 or 11 further including means for performing a cleaning process on the membrane wall to dislodge contaminant matter therefrom into liquid surrounding the membrane;
15 and means for removing said contaminant matter containing liquid through one or more of said openings.
13. A membrane filtration module according to claim 12 wherein the openings are used to introduce gas into the module to produce bubbles for scouring the surface of the membranes during said cleaning process.
- 20 14. A membrane filtration module including one or more membranes extending vertically from an upper header into which proximal ends of the membranes are potted, the membranes having a permeable wall which is subjected to a filtration operation wherein feed containing contaminant matter is applied to one side of the membrane wall and filtrate is withdrawn from the other
25 side of the membrane wall, the module further including one or more openings in

the module below said membranes wherein said feed, at least in part, is flowed through said openings for application to said membrane wall during said filtration operation.

15 15. A membrane filtration module according to claim 14 wherein the openings are used to introduce gas into the module to produce bubbles for scouring the surface of the membranes.

16. A membrane filtration module including one or more membranes extending longitudinally between vertically spaced upper and lower headers into which the ends of the membranes are potted, the membranes having a
10 permeable wall which is subjected to a filtration operation wherein feed containing contaminant matter is applied to one side of the membrane wall and filtrate is withdrawn from the other side of the membrane wall, at least one of said upper and/or lower headers having one or more openings therein, means
15 for performing a cleaning process on the membrane wall to dislodge contaminant matter therefrom into liquid surrounding the membrane; and means for removing said contaminant matter containing liquid through one or more of said openings.

17. A membrane filtration module according to claim 16 wherein the openings are provided in the lower header and filtrate is withdrawn from the upper header.

20 18. A membrane filtration module according to claim 16 or claim 17 wherein the openings are used to introduce gas into the module to produce bubbles for scouring the surface of the membranes during said cleaning process.

19. A membrane filtration module according to claim 16 wherein the removal of contaminant matter is performed concurrently with the cleaning process.

- 15 -

20. A membrane filtration system including a membrane filtration module, the membrane filtration module including one or more membranes located in a feed-containing vessel and extending longitudinally between vertically spaced upper and lower headers into which the ends of the membranes are potted, the
5 membranes having a permeable wall which is subjected to a filtration operation wherein feed containing contaminant matter is applied to one side of the membrane wall and filtrate is withdrawn from the other side of the membrane wall, at least one of said upper and/or lower headers having one or more openings therein, the membrane filtration system further including:

- 10 a) means for performing a filtration operation wherein said feed, at least in part, is flowed through said one or more openings for application to said membrane wall;
- b) means for suspending the filtration operation;
- c) means for performing a cleaning process on the membrane wall to
15 dislodge contaminant matter therefrom into liquid surrounding the membrane;
- d) means for performing a sweep or drain-down of the feed-containing vessel substantially parallel to the longitudinally extending membranes to remove the liquid containing the dislodged contaminant matter, at
20 least in part, through the openings in the header; and
- e) means for recommencing the filtration operation.

21. A membrane filtration system according to claim 20 wherein the openings are provided in the lower header and filtrate is withdrawn from the upper header.

22. A membrane filtration system according to claim 20 or claim 21 wherein the openings are used to introduce gas into the module to produce bubbles for scouring the surface of the membranes during said cleaning process.
23. A membrane filtration system according to claim 20 wherein the sweep is
5 performed concurrently with the cleaning process.
24. A membrane filtration system according to claim 20 wherein the feed-containing vessel is open to atmosphere.

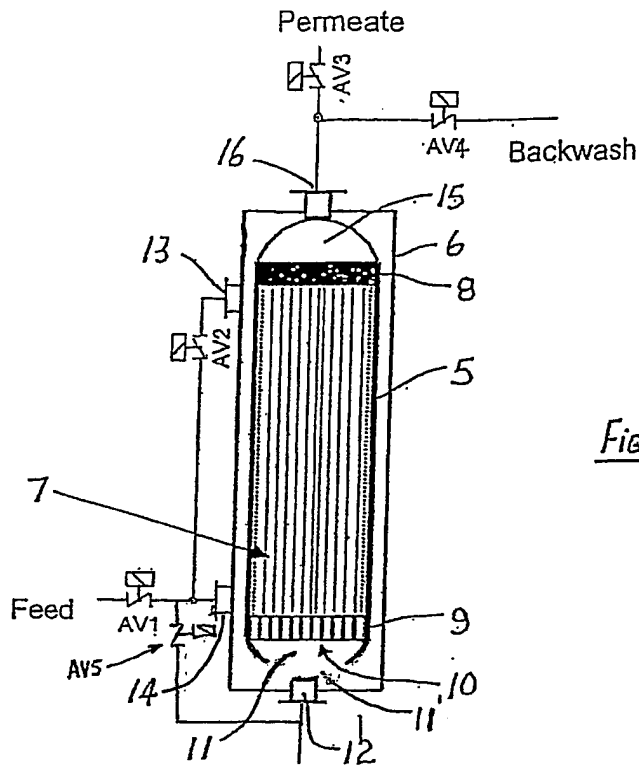

Fig. 1

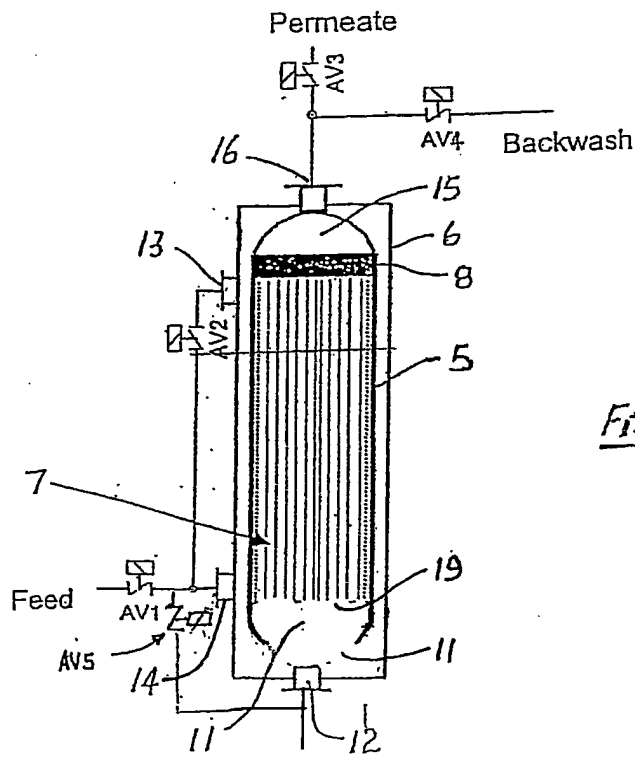

Fig. 2

FIG. 3a

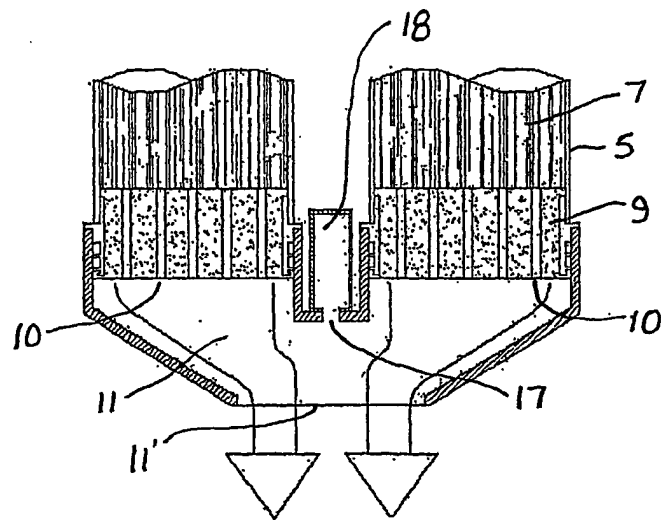
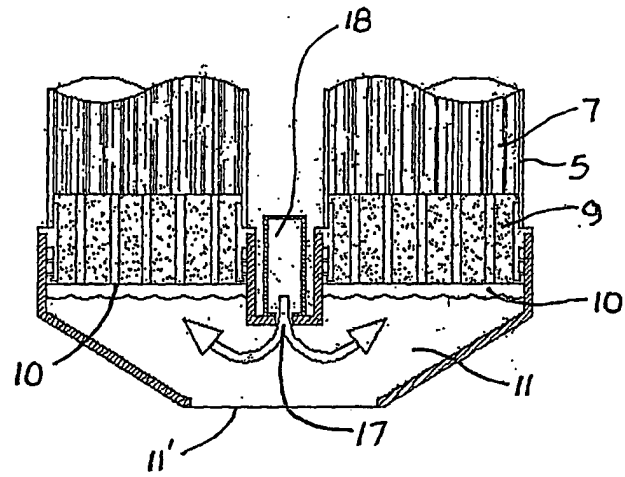

FIG. 3b

INTERNATIONAL SEARCH REPORT

International application No.
PCT/AU2005/001396

| | | |
|--|--|---|
| A. CLASSIFICATION OF SUBJECT MATTER | | |
| Int. Cl. ⁷ : B01D 65/02 | | |
| According to International Patent Classification (IPC) or to both national classification and IPC | | |
| B. FIELDS SEARCHED | | |
| Minimum documentation searched (classification system followed by classification symbols) | | |
| Documentation searched other than minimum documentation to the extent that such documents are included in the fields searched | | |
| Electronic data base consulted during the international search (name of data base and, where practicable, search terms used) Derwent DWPI: IPC B01D 65/02, 65/08, 61/02, 61/08, 61/14, 61/18, 61/24, 61/28, 63/02 and keywords POTT HEAD END HOLE OPENING APERTURE GAP SLIT PERFORAT | | |
| C. DOCUMENTS CONSIDERED TO BE RELEVANT | | |
| Category* | Citation of document, with indication, where appropriate, of the relevant passages | Relevant to claim No. |
| X | Derwent Abstract Accession No. 2003-857520/80, Class D15, JP 2003266072 A (ORGANO CORP) 24 September 2003 | |
| X | WO 2000/018498 A1 (USF FILTRATION AND SEPARATIONS GROUP INC.) 1 APRIL 2000 See whole document | |
| X | Derwent Abstract Accession No. 2000-231730/20, Class D15 J01, JP 2000051669 A (HITACHI ENG CO LTD) 22 February 2000 | |
| X | WO 2004/050221 A1 (U.S. FILTER WASTEWATER GROUP, INC.) 17 June 2004 See whole document | |
| <input checked="" type="checkbox"/> Further documents are listed in the continuation of Box C <input checked="" type="checkbox"/> See patent family annex | | |
| * Special categories of cited documents: "A" document defining the general state of the art which is not considered to be of particular relevance "E" earlier application or patent but published on or after the international filing date "L" document which may throw doubts on priority claim(s) or which is cited to establish the publication date of another citation or other special reason (as specified) "O" document referring to an oral disclosure, use, exhibition or other means "P" document published prior to the international filing date but later than the priority date claimed | "T" later document published after the international filing date or priority date and not in conflict with the application but cited to understand the principle or theory underlying the invention "X" document of particular relevance; the claimed invention cannot be considered novel or cannot be considered to involve an inventive step when the document is taken alone "Y" document of particular relevance; the claimed invention cannot be considered to involve an inventive step when the document is combined with one or more other such documents, such combination being obvious to a person skilled in the art "&" document member of the same patent family | |
| Date of the actual completion of the international search 17 November 2005 | | Date of mailing of the international search report 23 NOV 2005 |
| Name and mailing address of the ISA/AU AUSTRALIAN PATENT OFFICE PO BOX 200, WODEN ACT 2606, AUSTRALIA E-mail address: pct@ipaaustralia.gov.au Facsimile No. (02) 6285 3929 | | Authorized officer MATTHEW FRANCIS Telephone No : (02) 6283 2424 |

INTERNATIONAL SEARCH REPORT

International application No.

PCT/AU2005/001396

| C (Continuation). DOCUMENTS CONSIDERED TO BE RELEVANT | | |
|---|---|-----------------------|
| Category* | Citation of document, with indication, where appropriate, of the relevant passages | Relevant to claim No. |
| X | Derwent Abstract Accession No. 97-113396/11, Class D15 J01, JP 09000890 A (MITSUBISHI KAKOKI KAISHA) 7 January 1997 | |
| X | EP 280052 B1 (DONGBEI POWER COLLEGE) 27 July 1994 See whole document | |

INTERNATIONAL SEARCH REPORT

International application No.

PCT/AU2005/001396

This Annex lists the known "A" publication level patent family members relating to the patent documents cited in the above-mentioned international search report. The Australian Patent Office is in no way liable for these particulars which are merely given for the purpose of information.

| Patent Document Cited in Search Report | | Patent Family Member | | | | | |
|---|------------|----------------------|------------|----|------------|----|------------|
| JP | 2003266072 | | | | | | |
| WO | 0018498 | AU | 61834/99 | CA | 2342346 | CN | 1319032 |
| | | EP | 1115474 | NZ | 510394 | US | 6524481 |
| | | US | 6641733 | US | 6821420 | US | 6841070 |
| | | US | 2001047962 | US | 2003075504 | US | 2003205519 |
| | | US | 2004188341 | US | 2005109692 | | |
| JP | 2000051669 | | | | | | |
| WO | 2004050221 | AU | 2003291835 | BR | 0316992 | CA | 2508423 |
| | | EP | 1567249 | | | | |
| JP | 9000890 | | | | | | |
| EP | 0280052 | CN | 87100467 | FI | 880346 | JP | 63229104 |
| | | US | 4851136 | | | | |
| <p>Due to data integration issues this family listing may not include 10 digit Australian applications filed since May 2001.</p> <p style="text-align: right;">END OF ANNEX</p> | | | | | | | |